

# Sinks

## Models

BDSF4410X, BDSF4410GM, BDSF4410RG | BDSF5410X, BSF5410GM  
BDSF7620X, BDSF7620GM, BDSF7620RG, BDSF7620LG  
BDST7811XR, BDST7811XL | BDST1021XR, BDST1021XL  
BDST1121XR, BDST1121XL | BDST6010X

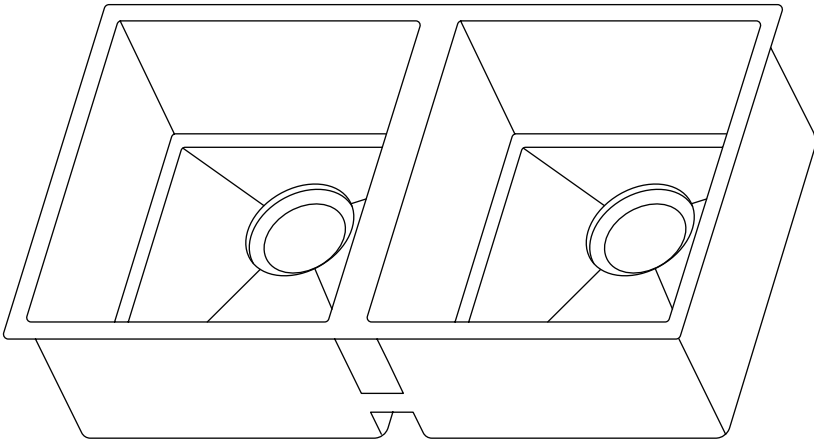

# WARRANTY

[bellling.com.au](http://bellling.com.au) | [bellling.co.nz](http://bellling.co.nz)

**PLEASE READ THE WARRANTY INFORMATION CAREFULLY BEFORE USING THE UNIT**

# CONGRATULATIONS

---

Dear Customer,

Congratulations on the purchase of your new product from **Belling**.

We recommend you please take some time to read the instruction manual thoroughly to familiarise yourself with the functionality and operations to ensure optimum performance of your new product.

After reading the manual, please store it in a safe and accessible location for future reference.

## **Installation**

The installation of your new sink must be carried out by a licensed plumber in accordance to local regulations. Please ensure all packaging materials are disposed of correctly.

## **Customer Care**

Our Customer Care centre is available should you wish to learn more about your appliance in relation to how to use it to its best potential, or tips on cleaning as well as available accessories.

For further details please contact our Customer Care Team

### **Australia**

Ph: 1300 556 816  
customer.care.ha@glendimplex.com.au

### **New Zealand**

Ph: 09 274 8265  
nztechserv@glendimplex.co.nz

Thank you.

Regards,

**Belling Australia and New Zealand**

---

## PRODUCT / INSTALLER DETAILS

**For future reference we suggest that you staple a copy of your purchase receipt here and complete the below so the information is always at hand.**

### PRODUCT DETAILS

Model number: \_\_\_\_\_

Description: \_\_\_\_\_

### PURCHASE DETAILS

Date of purchase: \_\_\_\_\_

Place of purchase: \_\_\_\_\_

Store name: \_\_\_\_\_

Address: \_\_\_\_\_

Telephone: \_\_\_\_\_ Invoice / receipt number: \_\_\_\_\_

### INSTALLATION DETAILS

#### Plumbing Details

Date of installation: \_\_\_\_\_

Company / installers name: \_\_\_\_\_

Licence number: \_\_\_\_\_ Telephone number: \_\_\_\_\_

- **Note:** Templates and dimensions are provided on the specification sheets and are included in the box, however, due to the small tolerances in the manufacture of these products, it is highly recommended to measure the actual sink to be installed before proceeding with a cut-out.

# FREQUENTLY ASKED QUESTIONS

---

## 1. Will my sink scratch?

Belling Design sinks are manufactured from genuine 18/10, 304 grade stainless steel, for optimum durability.

During the lifetime of the sink and with regular use, scratching of the sink will occur which is most noticeable when the sink is new.

Scratching is completely normal as no stainless steel sink is manufactured to withstand impact from hardened metal utensils, plates and other common items used in the kitchen. Overtime, scratches in the steel will appear less noticeable as your sink ages and it develops a unique finish where scratching eventually blends into the sinks grain.

## 2. Will my stainless steel sink rust? (Non-PVD models)

No, stainless steel sinks do not rust, however the appearance of rust may occur when certain contaminants come into contact with the steel.

Rust deposits on the surface of stainless steel sinks are generally due to one of the following factors:

- a) Steel wool pads: Often used for cleaning these will leave steel deposits on the sink which could cause rust marks to appear. Therefore direct use on the sink should be avoided.
- b) Ordinary steel containers, utensils or kitchen ware: Items like tin coated steel cans or pots can leave rust marks and stain the sink if they are left to sit for prolonged periods of time.
- c) Iron deposits: Often found in water, iron particles left on the sinks surface can lead to rust marks. Iron and metal filings are also common in new builds where water lines or new tapware that has been installed, have not been adequately flushed out.

In the instance that rust deposits form, we recommend to lightly scrub with a mild cleanser in the direction of the sink's grain. Particles need to be completely removed to stop them from returning and it is also important to thoroughly dry the sink after cleaning.

## 3. Is the sink suitable to pair with an Insinkerator and other waste disposal models?

Yes, our stainless steel kitchen sinks are compatible with any waste disposal model.

#### 4. What is PVD?

PVD is an innovative technology that deposits a very fine, thin layer of coloured metal film on a stainless steel sink.

PVD stands for physical vapor deposition. The process takes place inside a vacuum chamber where a precious metal, is evaporated, and the particles are deposited onto the product.

#### 5. How are the Belling Design sinks coloured and what is the process?

The colouring is achieved through Physical Vapour Deposition (PVD) which deposits a very fine and thin metal film onto a stainless steel sink.

Once the colour application is finished, a nano coating is applied to the sink which further enhances the surface making it resistance to mould and bacteria

#### 6. Does the waste match the colour of the sink?

Yes, the basket wastes and protective grid included, are colour matched with the sink.

#### 7. How do I clean and maintain my coloured sink?

All our sink and tap range, both stainless and coloured options, should be cared for in the same manner and cleaned with a mix of mild liquid detergent / soap and water. Following this step, they should then be rinsed and dried.

Furthermore, juices or acids from food should not be left to settle on the surface and should be cleaned off immediately as they can contain citric acids which over time can etch into the surface.

It is also highly recommended to use the protective grid provided with the coloured sinks, to protect the surface of the bowl from incidental damage and help maintain the appearance.

For further advice, please refer to the 'Product Care & Maintenance' section in the installation manual.

## FREQUENTLY ASKED QUESTIONS ---

### **8. What shouldn't I use to clean my sink?**

Never use harsh detergents, solvents or acidic cleaners, citrus based cleaners, lime scale removers, household vinegar, and cleaning agents containing acetic acid on any products as these will scratch and corrode a stainless steel sink.

Additionally, use of wax based furniture cream should be avoided as these can result in a build-up of deposits, which could detract from the appearance.

### **9. Is the colour on the PVD sinks guaranteed for 10 years?**

When the 'Product Care & Maintenance' guidelines are followed, the colour of the sink is guaranteed from fading, however it is not guaranteed against scratching and general wear and tear.

The colouring is a very fine, thin metal film on the surface of the stainless steel which will endure everyday use however if scratched harshly enough (i.e. gouged with a sharp knife), stainless steel could potentially show through.

### ALL PRODUCTS

Products should be cleaned with mild liquid detergent or soap and water.

Never use harsh detergents, solvents or acidic cleaners, citrus based cleaners, lime scale removers, household vinegar, and cleaning agents containing acetic acid on any products as these will scratch and damage the surface. Additionally, use of wax based furniture cream should be avoided as these can result in a build-up of deposits, which could detract from the appearance.

Do not use undue pressure when wiping.

Under no circumstances should products be installed using silicone.

### MAINTENANCE

Regularly clean or replace dirty or blocked outlet aerator inserts in tapware to ensure maximum functionality and longevity.

### PVD & NANO COATING (PVD COLOURED PRODUCT ONLY)

All PVD coated tapware has a NANO coating applied as the final step in the manufacturing process.

This coating has a hardening effect and provides the benefit of being resistance to mould and bacteria whilst protecting the tap from fading and scratching.

Whilst the NANO coating is a very hard and durable, care should still taken when cleaning the product as outlined in the product care and maintenance section of this manual.

# MANUFACTURER GUARANTEE

---

This warranty is provided in Australia by Glen Dimplex Australia Pty Limited ABN 69 118 275 460 (**Phone number 1300 556 816**) and in New Zealand by Glen Dimplex New Zealand Limited NZBN 9429000069823 (**Phone number 09 274 8265**) in respect of the **Belling** product.

## 1. Belling Express Warranty

**1.1** Glen Dimplex Australia provides the following warranty for all Belling Sink & Tapware Products purchased in Australia and New Zealand from an authorised reseller for use in domestic or commercial installations.

**1.2** This Express Warranty covers Belling Sinks & Taps and applies to defects which have arisen solely from faulty materials or workmanship in the products. For the avoidance of doubt, defects which arise as a result of the following are not covered by this warranty:

- a) Abuse, misuse, neglect, maltreatment, excessive stress or strain;
- b) Excessive water pressure or temperature (which do not comply with the recommended usage below);
- c) Repairs or alterations (other than by an accredited and licensed technician); and
- d) Attachments of accessories any kind (other than those approved by Glen Dimplex Australia).

**1.3** For the purpose of this Express Warranty, a Belling Product is a product which:

- a) Was manufactured by or on behalf of Glen Dimplex Australia;
- b) Bears a trademark owned by Glen Dimplex Australia;
- c) Was sold by an authorised reseller or distributor of Glen Dimplex Australia; and
- d) Was purchased in Australia or New Zealand for use in Australia or New Zealand.



**1.4** This Express Warranty commences on the earlier of:

- a) The date of purchase or, for new buildings, the date of handover; or
- b) The date of installation, provided the date of installation is no greater than twelve (12) months from the date of purchase, and will continue for the relevant periods set out in the warranty period tables below.

**1.5** It is the installer/consumer's responsibility to ensure:

- a) The product is not damaged prior to installation;
- b) The product has all of its components; and
- c) Required maintenance is performed on the product.

**1.6** The Express Warranties provided in this Warranty Card are personal to the Consumer who acquires the product from the relevant retailer for their own consumption or use and not for resale or resupply. Accordingly, claims made pursuant to this express warranty cannot be made by anyone other than the Consumer.

**1.7** If the Express Warranty:

- a) Is covered by a parts and labour warranty, the warranty covers both the repair of the defective part or the provision of a spare part to replace the defective part but does not cover the installation of that part to the extent that the installation requires the removal, alteration, repair or change to a connecting surface or any indirect or consequential building works; or
- b) Is covered by a parts only warranty, the warranty covers only the repair of the defective part or the provision of a spare part to replace the defective part and does not include the removal of the defective part or the installation of the repaired or replaced part.

**1.8** In this Express Warranty, special order, custom or discontinued items may be replaced by a reasonable alternative product and/or finish should a valid warranty claim occur.

# MANUFACTURER GUARANTEE

---

## 2. Warranty periods

Residential / Commercial: Glen Dimplex Australia warrants that the below products which are purchased by consumers for use in either the residential home or in commercial applications (e.g. hotels, aged care facilities, hospitals, schools, factories, motels) will be free from all defects in materials and workmanship for the periods specified below. Conditions apply to special order, custom or discontinued items, refer to section 1.8.

ⓘ Unless specified, labour is not included.

Category	Includes	Details
Tapware (Stainless Steel)	All models sold under the Belling brand	1 Year: Parts only. Hot & cold supply hoses / pull-out hoses / mixer hand pieces 5 Years: Parts & labour* 10 Years: Parts only (standard cartridge)
Tapware (PVD Finishes)	All models sold under the Belling brand	1 Year: Parts only. Hot & cold supply hoses / pull-out hoses / mixer hand pieces 5 Years: Parts & labour* 10 Years: Parts only (standard cartridge)
Sinks (Stainless Steel)	All models sold under the Belling brand	1 Year: Parts & labour 10 Years: Replacement only
Sinks (PVD Finishes)	All models sold under the Belling brand	1 Year: Parts and labour 10 Years: Replacement only
Sink Accessories	Drainer tray / roller mat / strainer bowl / chopping board	1 Year: Parts only
Wastes & Overflows	Plug / waste / seals / plastic tubing	1 Year: Parts only

\*Excludes damage to ceramic disc cartridges from pieces of copper tube, plastic tube, sand, dirt, or thread tape etc.

### 3. Consumer guarantees

Our goods come with guarantees that cannot be excluded under the Australian / New Zealand Consumer Law. You are entitled to a replacement or refund for a major failure and for compensation for any other reasonably foreseeable loss or damage. You are also entitled to have the goods repaired or replaced if the goods fail to be of acceptable quality and the failure does not amount to a major failure.

### 4. How to make a claim

**4.1** You may make a claim under this warranty through our website, contacting our customer care line or via email. Contact details for Glen Dimplex Australia and New Zealand can be found at the end of this document.

**4.2** To make a valid claim under this warranty, you must:

- a) Lodge the claim with us as soon as possible and no later than 14 days after you first become aware of the breakdown;
- b) Provide us with the product serial number;
- c) Provide us with reasonable proof of purchase for the product. This can take the form of a store receipt, new home handover form or other payment receipt documentation; and
- d) If required by us, provide us (or any person nominated by us) with access to the premises at which the product is located at times nominated by us (so that we can inspect the product).

### 5. Warranty claims

**5.1** If you make a valid claim under this warranty and none of the exclusions set out in section 2 apply, we will, at our election, either repair the product or replace the product with a product of identical specification (or where the product is superseded or no longer in stock, with a product of as close a specification as possible).

**5.2** Goods presented for repair may be replaced by refurbished goods of the same type rather than being repaired. Refurbished parts may be used to repair the goods. Products are designed and supplied for normal domestic use. We will not be liable to you under this warranty for business loss or damage of any kind whatsoever.

# NOTES

---

---

---

---

---

---

---

---

---

---

---

---

---

---

---

---

---

---

---

---

---

---

---





## READ THE INSTRUCTION BOOKLET BEFORE INSTALLING AND USING THE APPLIANCE.

The manufacturer will not be responsible for any damage to property or to persons caused by incorrect installation or improper use of the appliance. The manufacturer is not responsible for any inaccuracies, due to printing or transcription errors, contained in this manual. In addition, the appearance of the figures reported is also purely indicative.

The manufacturer reserves the right to make changes to its products when considered necessary and useful, without affecting the essential safety and operating characteristics. Glen Dimplex constantly seeks ways to improve the specifications and designs of their products. Whilst every effort is made to produce up to date literature, this document should not be regarded as an infallible guide. Actual product only should be used to derive cut out sizes.

All appliances must be installed by a qualified person/s with adherence to the relevant electrical, plumbing and building codes, with compliance being issued as required by state or national legislation.

Additionally, all upright cookers must have the anti-tilt device installed correctly in adherence to the relevant standards by a licenced installer.

For maximum effectiveness and efficiency all rangehoods should be installed with the use of ductwork, by a licenced installer with adherence to the relevant state and national building codes and regulations.

All Glen Dimplex appliances are for Domestic use only, and must be installed by a licenced installer into Domestic Applications only, without exception and to the required Authorities guidelines. Any installation outside of this will **VOID** warranty. Alfresco areas are not a Domestic application.



Distributed by

### **Glen Dimplex Australia Pty Ltd**

Ph: 1300 556 816  
customer.care.ha@glendimplex.com.au

For service advice, please contact the Customer Care Centre by phone or email above.

For full terms and conditions, or to register your product warranty, please visit our website:

[www.glendimplex.com.au](http://www.glendimplex.com.au)

### **Glen Dimplex New Zealand Ltd**

Ph: 09 274 8265  
nztechserv@glendimplex.co.nz

[www.glendimplex.co.nz](http://www.glendimplex.co.nz)



[belling.com.au](http://belling.com.au) | [belling.co.nz](http://belling.co.nz)